

Technical Specification - GreaseShield® 1850-F



GreaseShield®

The Grease Management Solution

APPLICATIONS

- Large Pot Wash Sink
- Triple Bowl Sink

FLOW RATES & CERTIFICATION

- Pro-Active Flow Rate - 1.85 L/sec
- ASME Certification
- PDI Certification
- CSA Certification
- EN 1825 Certification

STANDARD FEATURES & FUNCTIONS

- Automatic FOG & solids removal
- Self cleaning
- Magnetic baffle for bioremediation
- PLC controlled
- Non restricted Vortex Flow Control device
- Reverse flow configuration
- Grey water recirculation
- Space Saver Running Trap & Sampling Point
- Globally certified award winning technology
- The only Green Certified grease trap in the world



**Environmental
Products and Services Ltd**

Award Winning Technology

Plumbing Connections

FilterShield™ Inlets	1" 1/2/40mm
Inlet	1" 1/2/40mm
Invert Inlet	1" 1/4/32mm
Outlet	2"/54mm
Decant Outlet	3/4"/18mm
Hot Water Solenoid	3/4"/22mm

Electrical Ratings

	USA	UK,EU,AU,NZ
Voltage	120v	230v
Frequency	60Hz	50Hz
Current	0.98A	0.49A

Standard Operational Times

Days of Operation	7 Days a Week
Hours of Operation	07:00-02:30

Note: Operational times should be adjusted to suit the needs of the kitchen

Average Power Consumption

15.8W Per Hour

CERTIFICATIONS & APPROVALS

- Global GreenTag LCA Rate Gold Certification
- PDI G101 (Plumbing & Drainage Institute)
- ASME A112.14.3 & A112.14.4 (American Society of Mechanical Engineers)
- NSF International (National Sanitation Foundation)
- CSA (Canadian Standards Association) - Grease Interceptors
- UL (Underwriters Laboratory)
- IAPMO (International Association of Plumbing and Mechanical Officials) Uniform Plumbing Code Certification Mark
- UKCA (UK Conformity Assessed)
- CE - Conformity with Health, Safety and Environmental Protection \ Standards with the European Economic Area (EEA)
- EN1825 (European Standard for Grease Separators)
- KIWA (ETA DK, Swedac & SINTEF) - Sweden, Norway and Finland. European Institution for Testing, Inspection and Certification
- SHASE-S 217:2016 (Japanese Grease Management Standard for Grease Interceptors)

V9 09/09/2021

www.GreaseShield.com

HEAD OFFICE +44 (0) 28 3083 3081

sales@epas-ltd.com

GB OFFICE +44 (0) 161 477 5555

Technical Specification - GreaseShield®1850-F

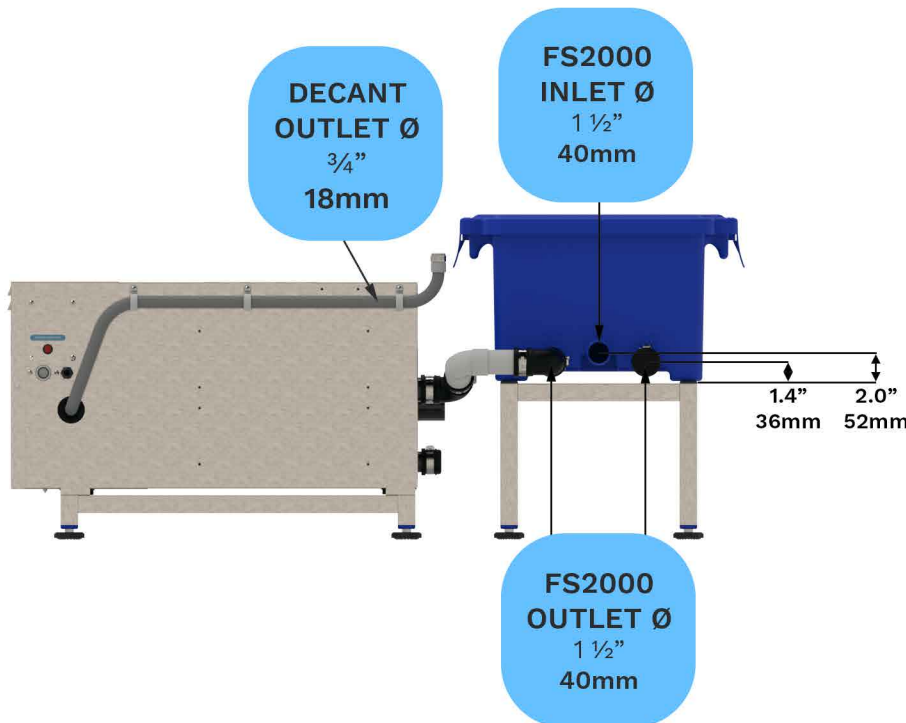
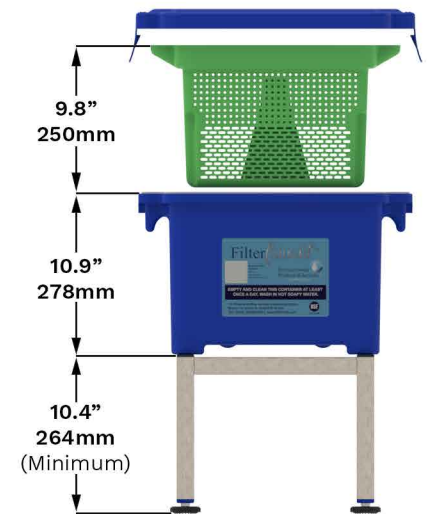
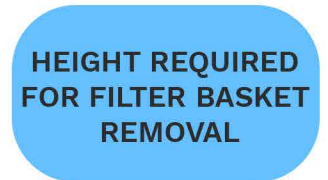
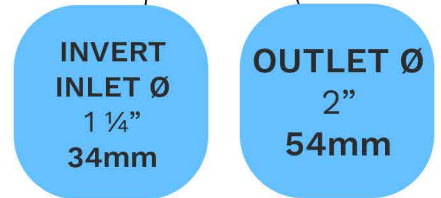
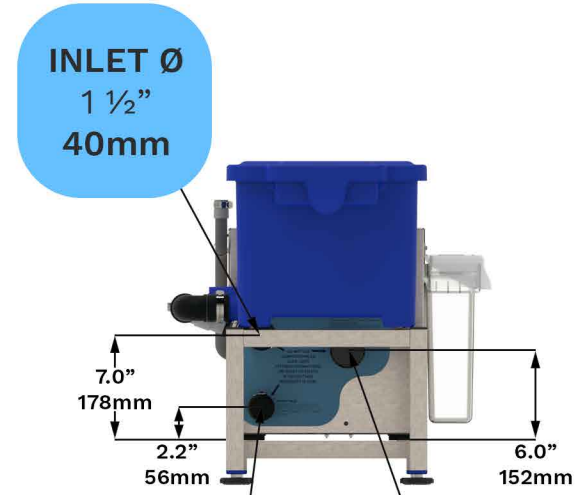
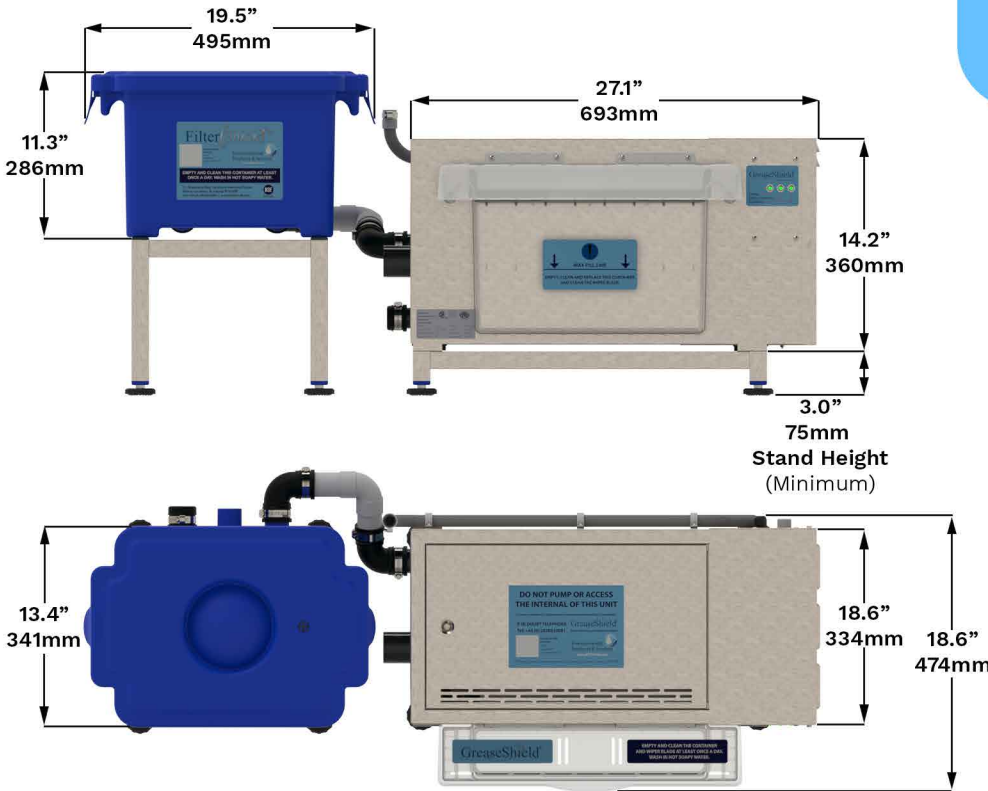

Environmental Products and Services Ltd

Award Winning Technology

www.GreaseShield.com

HEAD OFFICE +44 (0) 28 3083 3081

sales@epas-ltd.com

GB OFFICE +44 (0) 161 477 5555

V9 09/09/2021